

Products

Mounting Plate GPL

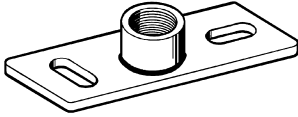

Support Cone SMD 1

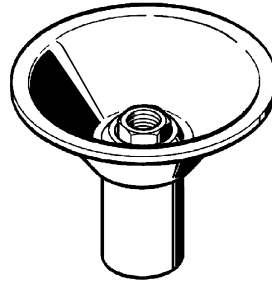

Threaded Tube GR

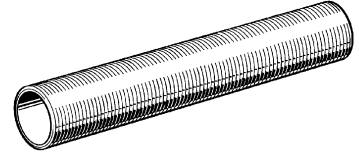

Support Bracket WK

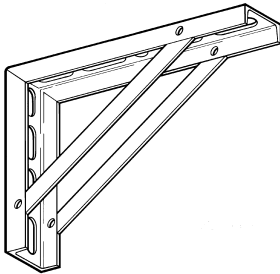

Tie Rod STR

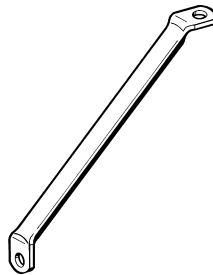

Sound Absorber SDE 1

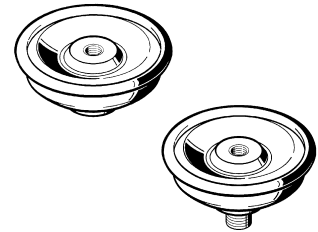

Fixed Point Clamp FS

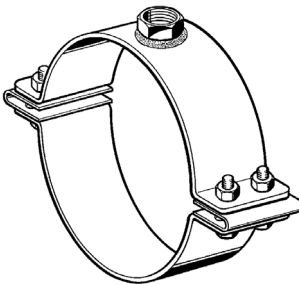

Mounting Kit VP

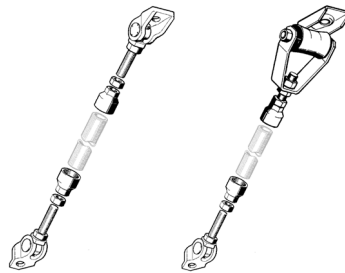

A/B; SDE 2

**Fixed Point
(trestle arrangement)**

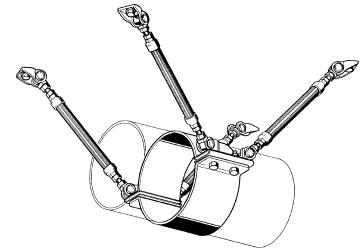

Sound Absorber SDE 2 - FP 1

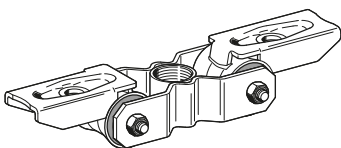

**Chilled Water Fixed Point
Clamp FKS**

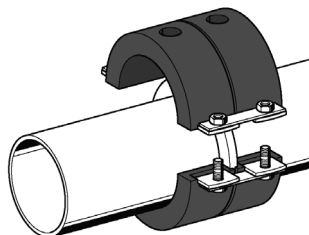

Sealant DP 30/45

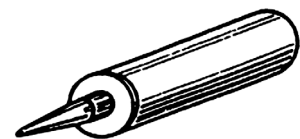

Basic Assemblies

Mounting Plate GPL Stabil 1" with Sikla Threaded Tube for fixed points up to 3 kN

The Mounting Plate has to be oriented in the direction of the force!

Calculate anchor loads separately!

Locking Nut for fixing the position

Threaded Tube GR

Adapter AD

Pipe Clamp Stabil D-3G

The longer the Threaded Tube, the lower the allowed fixed point force

FP

Fixed points must resist the forces along the pipe axis, which occur

(1) due to temperature changes (expansion of the pipe) and/or

(2) due to hydrostatic pressure in „open“ systems (e.g. systems with axial expansion joints)

combination of forces:

$$FP(1) = FR + FB$$

$$FP(2) = FR + FH + FF$$

FP = Fixed Point Force

FR = Friction Force

FB = Bending Force (bending leg)

FH = Force resulting from hydrostat. Pressure

FF = Spring Force (expansion joint)

In order to safely avoid the pipes from slipping in the pipe clamps, stoppers have to be installed.

At the fixed point the max. dislocation of a pipe should not exceed 3 mm.



Support Cone SMD 1 3/4" with Threaded Tube for fixed points up to 3 kN

Single point mounting with Bolt Anchor AN BZ PLUS M12/30

The longer the Threaded Tube, the lower the allowed fixed point force.

Additional bracing in the axis of the applied force cater for higher fixed point forces up to approx. 7kN.

Two-point arrangements can cater for higher fixed point forces.

The load carrying capacity of the Support Cone SMD 1 is independent of the direction of force applied.

Trestle Arrangement (Assembly and Scope of Delivery)

Trestle arrangement for fixed points up to 35 kN

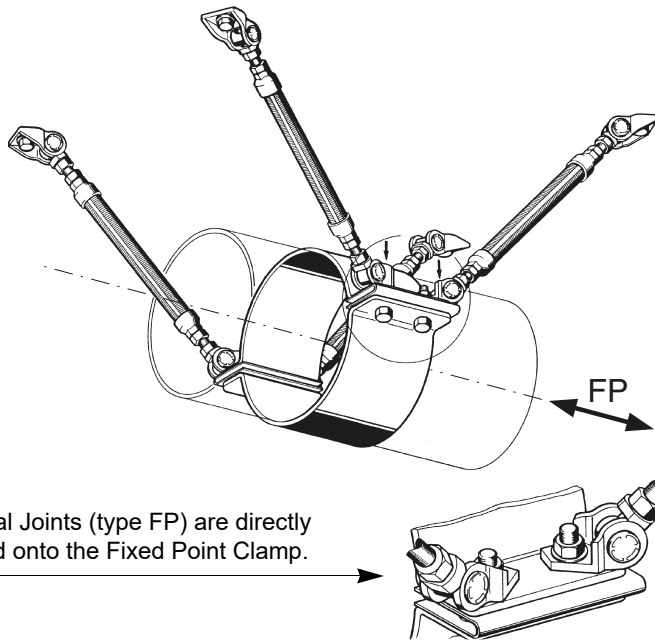

Universal Joints (type FP) are directly mounted onto the Fixed Point Clamp.

For the dimensioning of a Fixed Point in trestle arrangement, the following information is required

- Diameter of the pipe
- Fixed point force and the
- Distance of the pipe axis from the building structure.

Based on this information, our technical department will determine the components for the Fixed Point Package:

- ① Fixed Point Clamp FS
- ② Mounting Kit VP
- ③ Braces

in the dimensions required.

The greater the distance between the pipe and the supporting structure, the more solid the trestle arrangement should be.

Note:

- ▶ There are two versions available, either with an angle of 45° or with 30° when space is limited.

Each assembly consists of 3 components:

① Fixed Point Clamp FS

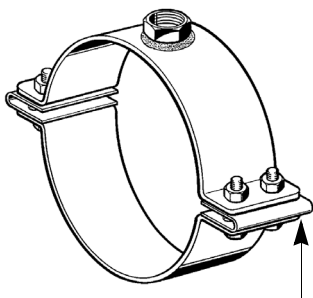

The spring inserts allow for absorbing high pipe anchor forces (up to approx. 15kN), without the need for welded stoppers.

Caution!

- ▶ When pipe anchor forces are particularly high, or specific regulations have to be observed, additional means are necessary to cater for shear forces.

② Mounting Kit VP

The Mounting Kit contains Threaded Stud GST, Universal Joints UG and Adapters AD for 4 braces.

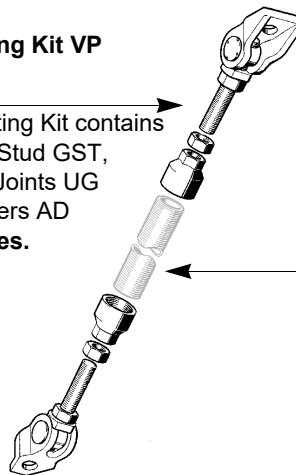

③ Threaded Tubes GR or Threaded Rods GST as braces

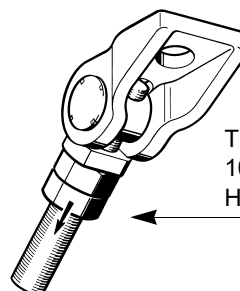
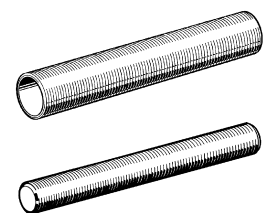

The Universal Joints UG are pre-assembled. 100 mm Threaded Studs GST and an additional Hexagon Nut NT already fixed.

Soundproof Fixed Points

Support Bracket WK with Tie Rods STR on Sound Absorbers SDE 1 for fixed points up to 1.5 kN

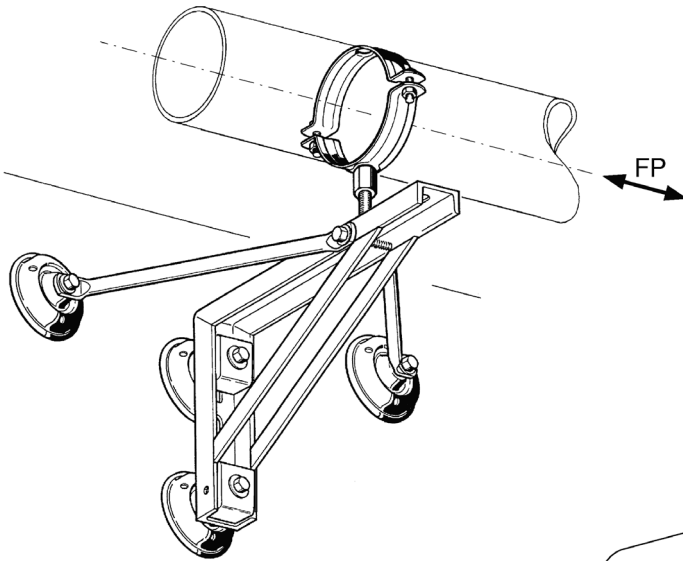

Sound Absorbers SDE 2 - FP 1 for fixed points up to 3 kN

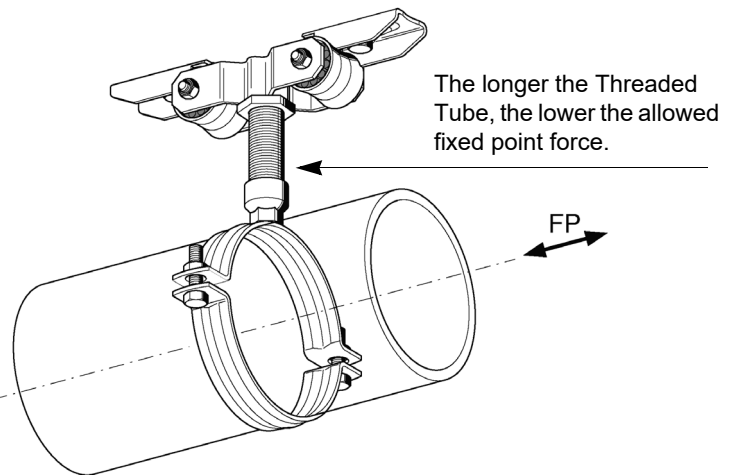

Trestle arrangement with 4 SDE 2-UG 16, for soundproof fixed points up to 25 kN (Type A, 45°)

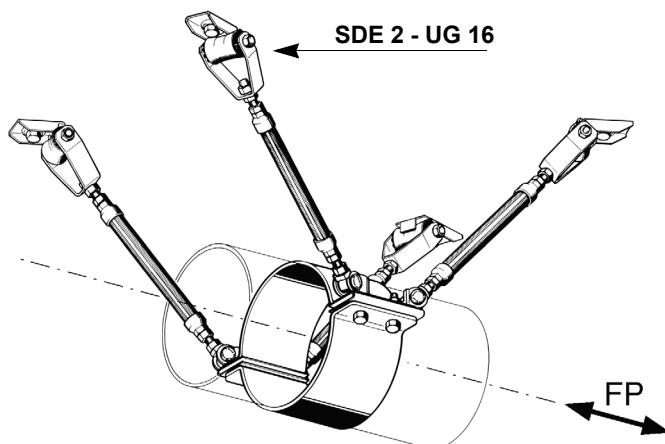

Pipe Clamps with rubber lining can be used as soundproof fixed points, however only in case of low fixed point forces.

For higher force-resistance requirements, clamps without lining are used, and the sound absorption is provided at the connection to the sub-structure.

Highly resilient Fixed Points with a high sound absorption (up to 15 dB (A)) can be catered for when using a trestle arrangement including 4 SDE 2 Sound Absorbers UG 16 and a Fixed Point Clamp.

Caution!

► When requirements are particularly high or specific regulations have to be considered, additional means are necessary to cater for shear forces.

Procedure for designing of trestle arrangement

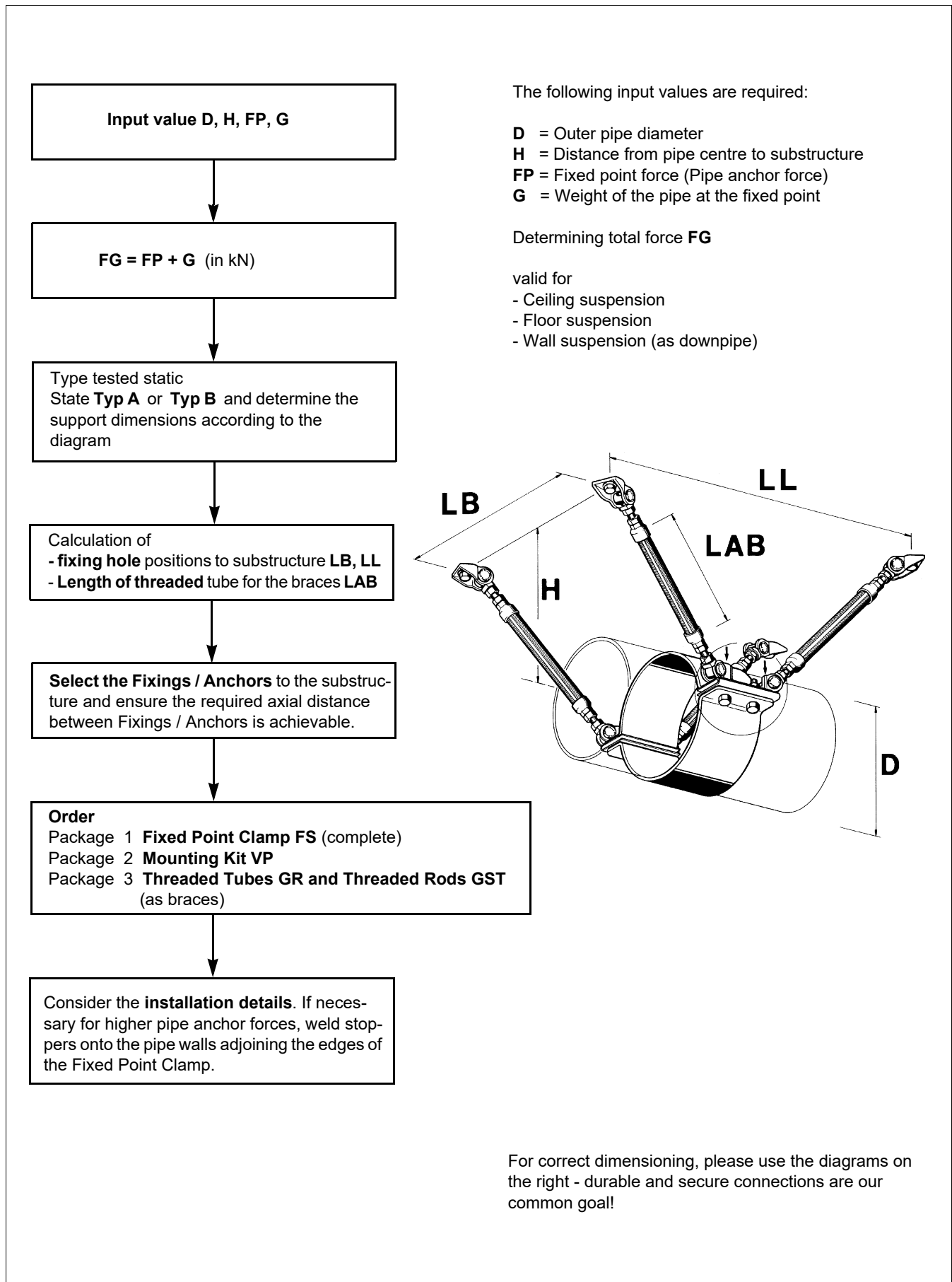

Type tested static for trestle arrangement Type A (45°) and type B (30°)

Typ A (45°) for higher fixed point forces

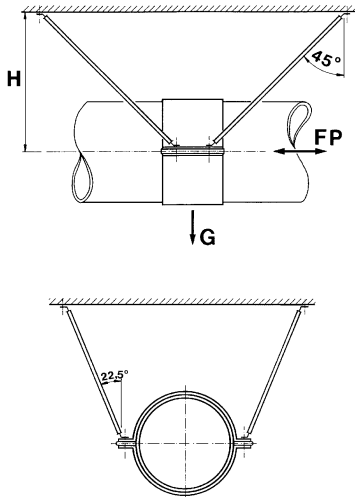

$$FG = FP + G$$

Symmetrical construction allows for the maximum fixed point force in either axial direction.

The diagram is valid for trestle arrangements without sound insulation up to 35 kN. For the type with sound insulation the loading limit is 25 kN.

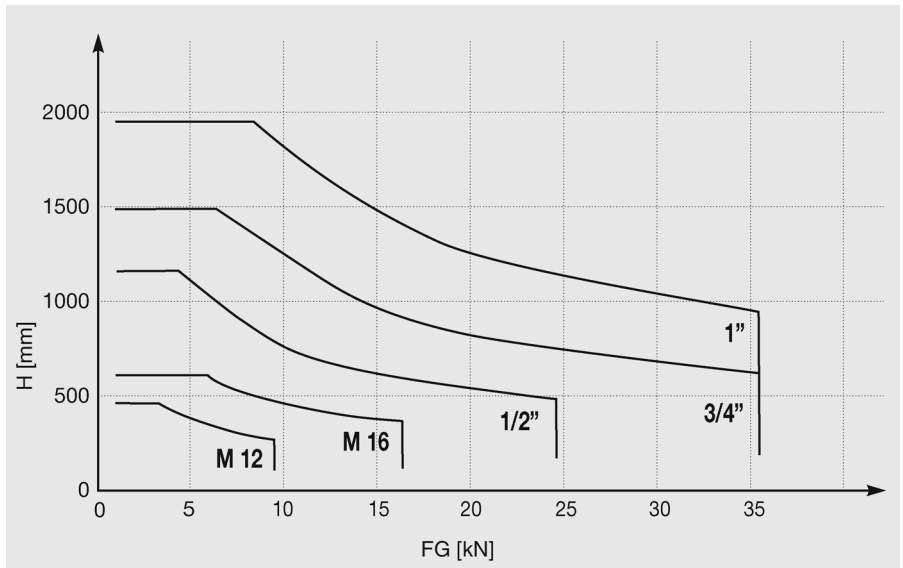

Typ B (30°) for narrower space limitations

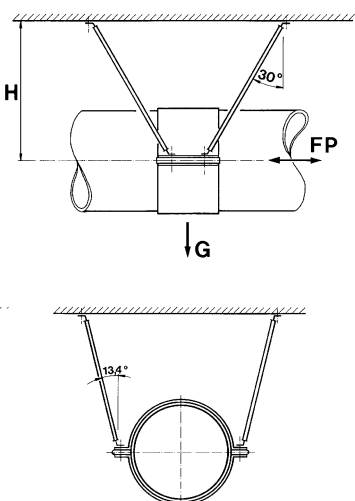

$$FG = FP + G$$

The diagram is valid for trestle arrangements without sound insulation up to 26 kN. For the type with sound insulation the loading limit is 18 kN.

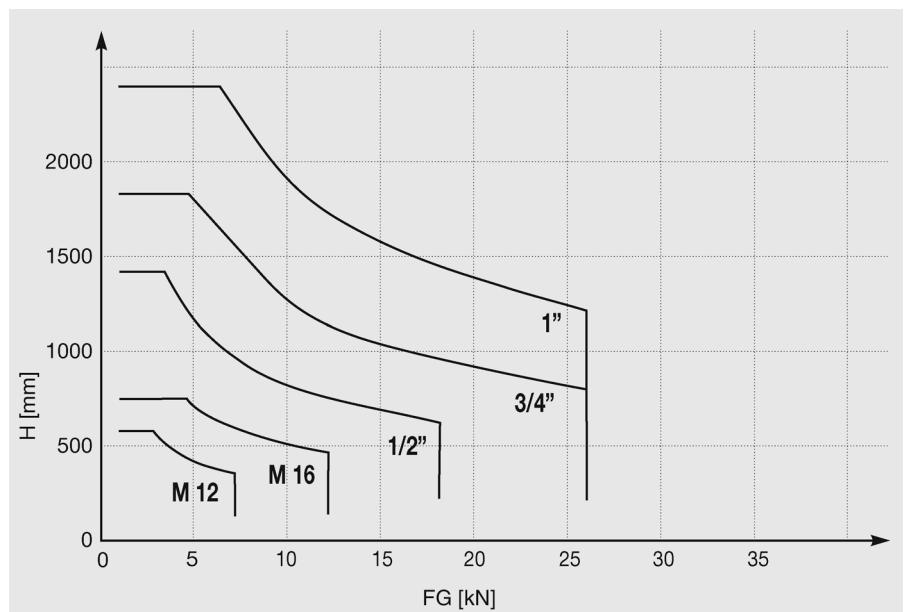

Chilled Water Fixed Point Clamp FKS - Installation to the pipe

Preparation

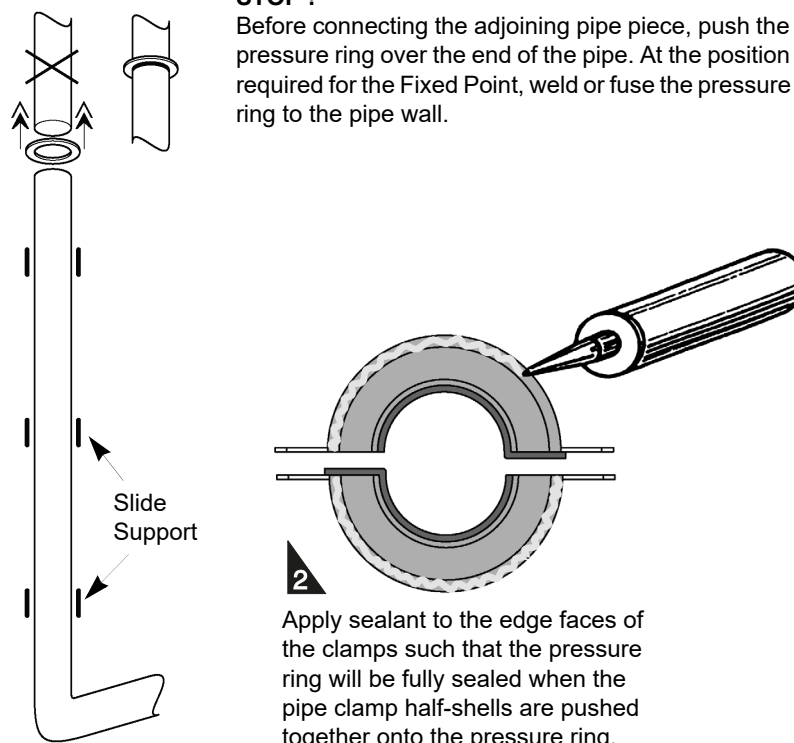

1
STOP !
Before connecting the adjoining pipe piece, push the pressure ring over the end of the pipe. At the position required for the Fixed Point, weld or fuse the pressure ring to the pipe wall.

2
Apply sealant to the edge faces of the clamps such that the pressure ring will be fully sealed when the pipe clamp half-shells are pushed together onto the pressure ring.

Slide Support

Chilled Water pipes are subject to changing length. Slide Supports are necessary to accommodate this contraction and expansion of the pipe.

"Normal" Chilled Water Clamps and insulation inserts exert minimal clamping force to the pipe wall, so the axial thrust force on the Fixed Point has to be borne by the edge bearing surfaces of the pipe clamp shells (insulant material).

The pressure ring which is welded to the pipe wall, takes over this function and transfers the axial forces to the adjoining pipe clamp shell which is geometrically formed to fit against the pressure ring when installed.

Note:

► *If the pressure ring has not been welded to the pipe during the pipe run installation, the pressure ring should be split and welded carefully around the pipe to ensure a consistent axial force resistance when used as the Fixed Point bearing ring.*

Installation Sound Absorber

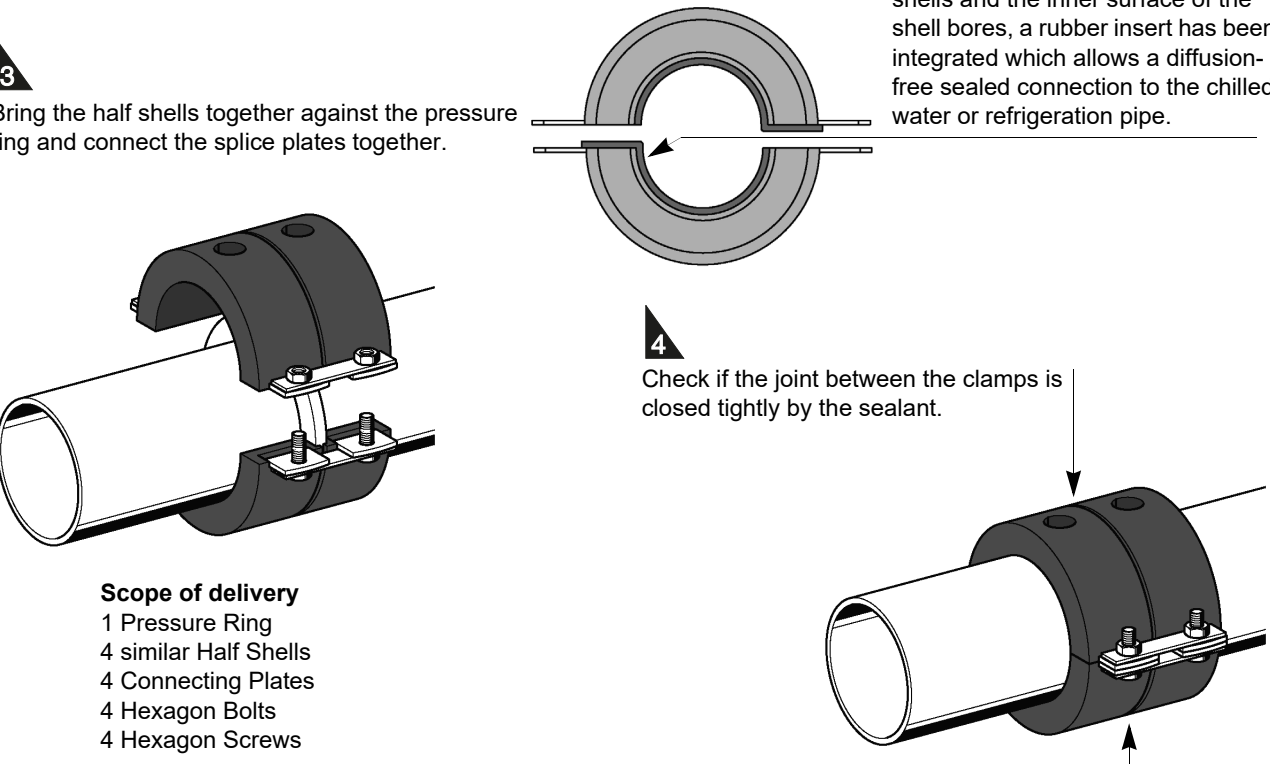

3
Bring the half shells together against the pressure ring and connect the splice plates together.

4
Check if the joint between the clamps is closed tightly by the sealant.

Between the cut edges of the pipe shells and the inner surface of the shell bores, a rubber insert has been integrated which allows a diffusion-free sealed connection to the chilled water or refrigeration pipe.

Scope of delivery
1 Pressure Ring
4 similar Half Shells
4 Connecting Plates
4 Hexagon Bolts
4 Hexagon Screws

Chilled Water Fixed Point Clamp FKS - Installation to the building structure

Trestle Arrangement

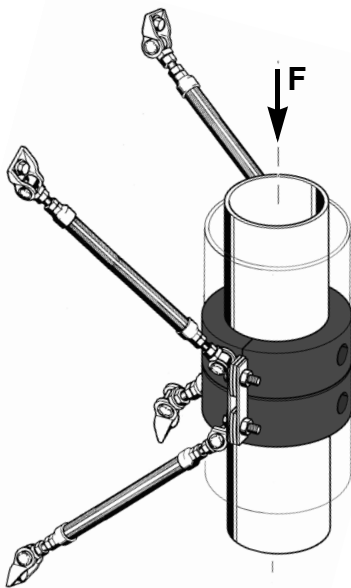

The self-weight of pipes in a riser can be borne by the Chilled Water Fixed Point Clamp.

The centric thread connectors can be used for supporting the weight of a horizontal pipe.

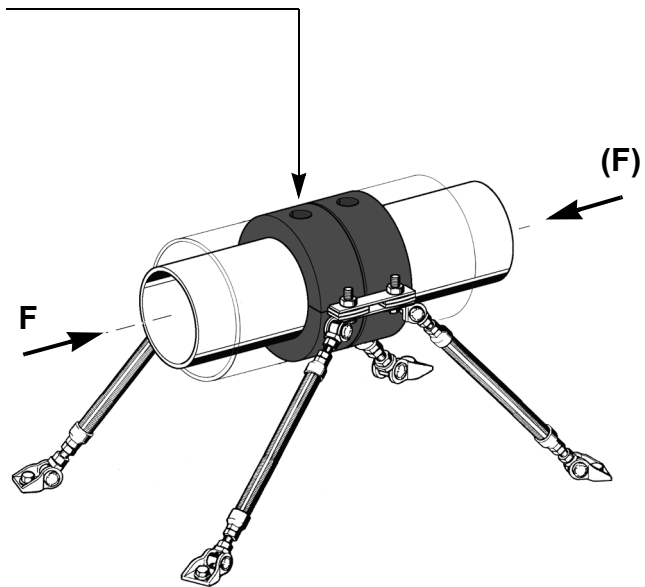

Trestle arrangement for sound-proofed fixed points

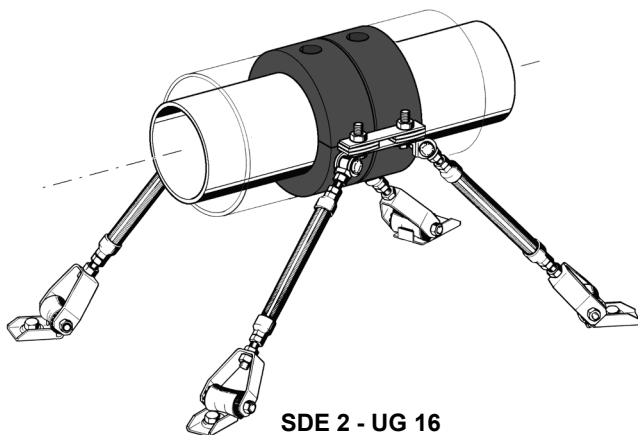

SDE 2 - UG 16

The symmetrical trestle arrangement allows for the pipe anchor forces to be resisted in either axial direction, and will be transferred appropriately into the building substructure to which it is attached.

Chilled Water Fixed Point Clamp with suitable Mounting Kits VP - two versions are available:

- without sound absorption (Mounting Kit VP A/B with UG)
- with sound absorption (Mounting Kit VP SDE2).

Note:

- ▶ A compressive strength of 0.6 N/mm^2 is used for determining the allowable static compressive strength resistance of the PUR clamp material (density 250 kg/m^3).